



NSG 4070C TEST SYSTEM FOR CONDUCTED AND RADIATED IMMUNITY



- **Integrated signal generator**
4 kHz to 1 GHz
- **3 power meter inputs**
4 kHz to 1 GHz
- **Integrated class A power amplifier module for different applications:**
35 W, 150 kHz to 230 MHz;
40 W, 10 kHz to 400 MHz;
45 W, 9 kHz to 1 GHz;
60 W, 10 kHz to 400 MHz (>10 W at 4 kHz);
80 W, 150 kHz to 230 MHz
110 W, 10 kHz to 400 MHz (>10 W at 4 kHz);
- **Multiple EUT monitoring options**
- **5,7" TFT color display**
- **Internal, menu-based control software**
- **Basic remote control software and report generator included**
- **Optically decoupled remote control**
- **Whisper mode**

Standards:

- IEC / EN 61000-4-3
- IEC / EN 61000-4-6
- IEC / EN 61000-4-20
- IEC / EN 61000-4-21
- IEC 62132
- ISO 11452-4
- MIL-STD-461 CS114
- Ford FMC1278
- GM GMW3097
- Nissan 28400NDS
- Peugeot PSA B21 7110
- Renault 36-00-808
- And others

The NSG 4070 is a multi-functional device for carrying out EMC immunity tests to accompany development and conformity testing in accordance to IEC/EN 61000-4-6, Namur and several automotive BCI standards. Anyone who spends a considerable amount of time on test level setting, connecting EUT monitoring or writing test reports can now carry out immunity testing in a much more efficient manner with the 4th generation of NSG 4070.

Its modular set-up using internal or external amplifiers enables a large variety of applications. The powerful and easy to use firmware makes the NSG 4070 independent from an external PC and control software, however it can also be remote controlled for system operation. A state-of-the-art data transfer of test and measurement data for documentation is provided by USB stick to be plugged into the front panel.

Model range and applications

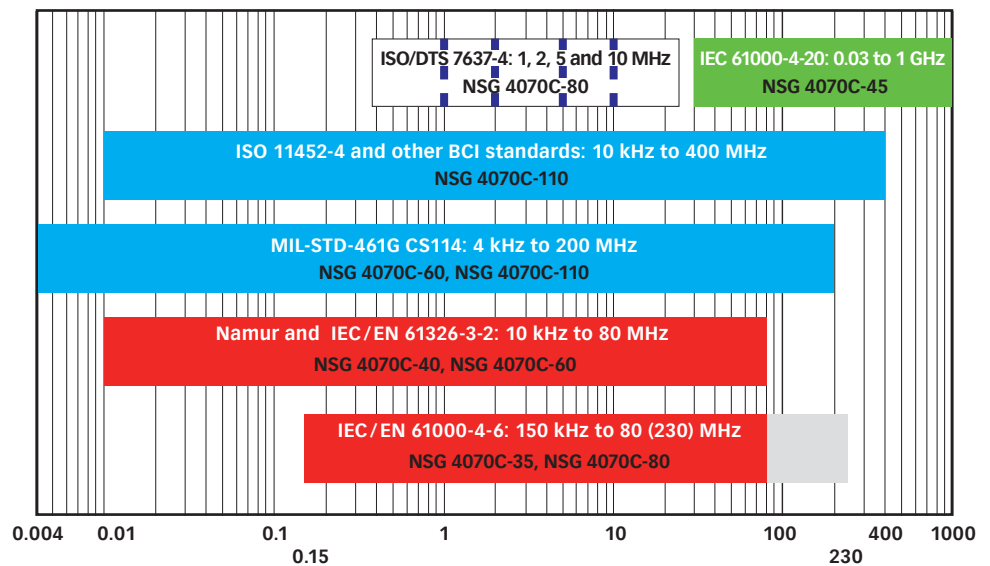

Frequency in MHz

- Induced RF - test levels in Volts , ■ Extended range by some product standards
- Bulk Current Injection (BCI) - test levels in mA or dBµA,
- Pulsed sinusoidal disturbances - test levels in Vpp,
- Radiated fields - test levels in V/m

Note: Regardless of the built-in amplifier module, each NSG 4070 can be combined with an external power amplifier and directional coupler to provide maximum flexibility in the EMC laboratory. Of course, other NSG 4070 models than those shown here in the overview can also be used, as shown in the table on the next page.

NSG 4070C TEST SYSTEM FOR CONDUCTED AND RADIATED IMMUNITY

Selection guide for the power amplifier

Product	Power amplifier nominal power	Power amplifier frequency range	Immunity testing IEC/EN 61000-4-6) ¹ 150 kHz to 230 MHz			Immunity testing Namur) ¹ 10 kHz to 80 MHz			Automotive BCI testing) ² ISO 11452-4: 2011		Automotive BCI testing Ford FMC1278) ²		MIL-STD-461G CS114) ²	RTCA DO-160G CS Test) ²
			CDN	EM clamp	Current injection probe	CDN	EM clamp	Current injection probe	Substitution	Closed loop with k = 4	Substitution	Closed loop with k = 4	Substitution	Closed loop with k = 4
NSG 4070C-0		-	*	*	*	*	*	*	*	*	*	*	*	*
NSG 4070C-0 + external amp	260 W (>10W at 4 kHz)	10 kHz (4 kHz) to 400 MHz	30 V	30 V	15 V	30 V	11 V	3 V	600 mA > Level IV	300 mA > Level IV	115 dBµA Level 2	109 dBµA Level 2	114 dBµA Level 5	300 mA Level: M, Q, R, S, T, W, Y
NSG 4070C-110)³	110 W (>10W at 4 kHz)	10 kHz (4 kHz) to 400 MHz	30 V	26 V	10 V	30 V	7 V	2 V	400 mA > Level IV	200 mA > Level IV	112 dBµA Level 2	106 dBµA Level 2	114 dBµA Level 5	200 mA Level: M, R, S, T, W
NSG 4070C-80	80 W	150 kHz to 230 MHz	30 V	22 V	8 V	*	*	*	*	*	*	*	*	*
NSG 4070C-60)³	60 W (>10W at 4 kHz)	10 kHz (4 kHz) to 400 MHz	27 V	19 V	7 V	27 V	5 V	1 V	300 mA > Level IV	150 mA Level III	109 dBµA Level 2	103 dBµA Level 1	109 dBµA Level 5	150 mA Level: M, R, S, T, W
NSG 4070C-45	45 W	9 kHz to 1 GHz	24 V	17 V	6 V	24 V	5 V	1 V	260 mA > Level IV	130 mA Level III	108 dBµA Level 2	102 dBµA Level 1	108 dBµA Level 5	130 mA Level: M, R, S, T
NSG 4070C-40	40 W	10 kHz to 400 MHz	22 V	16 V	6 V	22 V	4 V	1 V	240 mA > Level IV	120 mA Level III	108 dBµA Level 2	102 dBµA Level 1	108 dBµA Level 5	120 mA Level: M, R, S, T
NSG 4070C-35	35 W	150 kHz to 230 MHz	21 V	15 V	5 V	*	*	*	*	*	*	*	*	*

All level calculated in relation to the standard requirements with typical values of the coupling device.

¹⁾ Calculated with 6 dB attenuator and AM with 80% modulation depth.

²⁾ Calculated with highest test level in the frequency range and related typical insertion loss of the BCI probe Teseq CIP 9136A.

³⁾ NSG 4070C-60 and NSG 4070C-110 measure the reverse power also with selected internal power amplifier (5 channel power meter and bidirectional coupler) as may required by the BCI standard.

*) Requires external directional coupler and external power amplifier for the frequency range and test level.

NSG 4070C TEST SYSTEM FOR CONDUCTED AND RADIATED IMMUNITY

Front panel

- External access to signal generator output and power amplifier input and output
- 3 power meter inputs
- 5.7" color display, easy to use firmware
- Hard keys for important functions

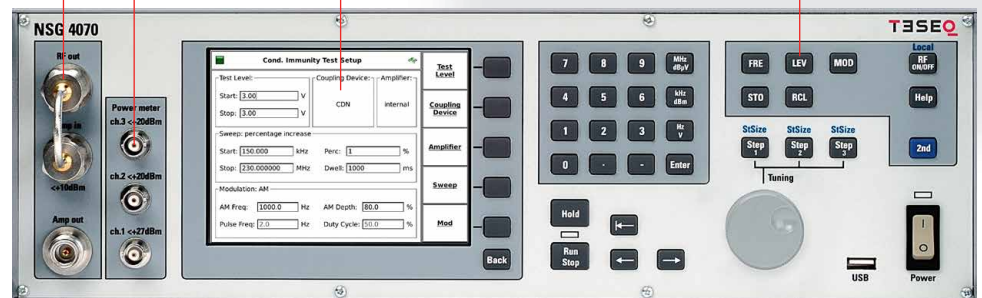

Back panel

- User port for 4 TTL inputs and 4 TTL outputs and supply voltages for individual monitoring and control applications
- Analog, digital and optical monitoring inputs for extensive EUT monitoring options
- Remote control via optical RS232, RS232, LAN or USB
- 2x USB, 10 MHz reference output, Trigger input, external modulation input



T E S E Q

Advanced Test Solutions for EMC

NSG 4070C TEST SYSTEM FOR CONDUCTED AND RADIATED IMMUNITY

Block diagram of NSG 4070

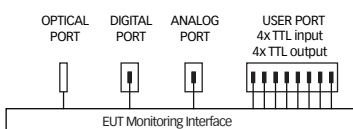
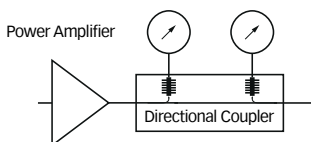
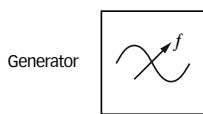
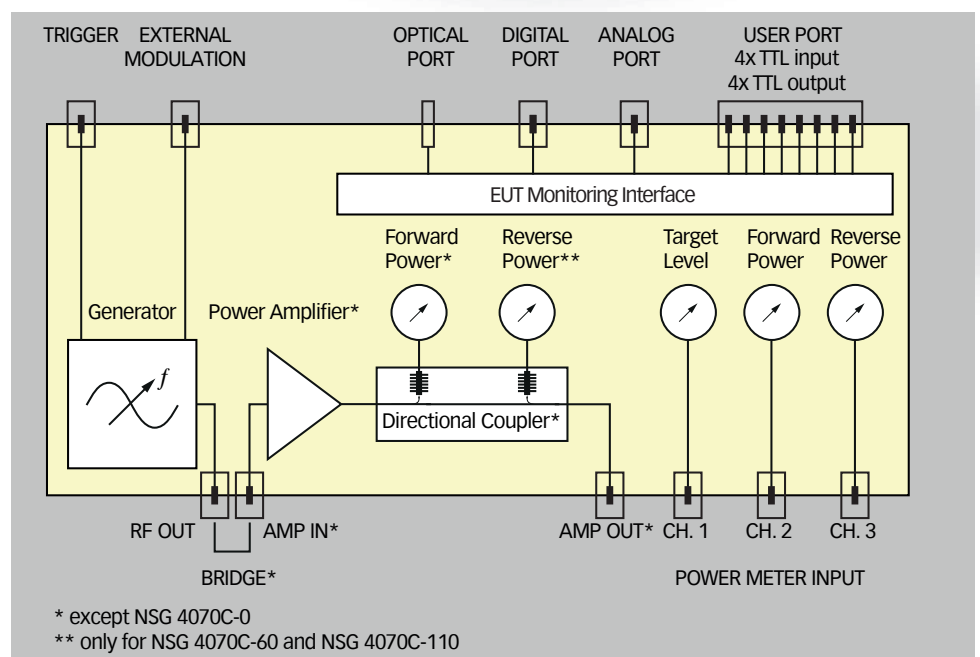

The heart of the device is the signal generator, which generates the sinusoidal signal over the wide frequency range from 4 kHz to 1 GHz and in the level range -60 dBm to +10 dBm. The built-in modulator allows amplitude and pulse modulation. The NSG 4070C contains extended parameters for pulse modulation and allows up to three envelopes to be interleaved. One input allows modulation from an external source.

The output of the signal generator is connected to the internal power amplifier via a bridge. Next to the amplifier a directional coupler is connected to measure the forward power. The NSG 4070C-60 and NSG 4070C-110 additionally measure the reverse power at the internal directional coupler. All NSG 4070 devices can measure forward and reverse power via an external directional coupler. For this application, power meter inputs 2 and 3 are located on the front panel. The power meter input 1 is intended for adjusting the target value and for connecting the current probe.

The EUT monitoring interface allows the simple and fast integration of the interfaces of the EUT to be monitored. The TTL inputs and outputs of the NSG 4070 can be used to integrate additional equipment for monitoring test specimens. The optical EUT monitoring input can detect the status of an indicator lamp. When using the extensive EUT monitoring functions, the user receives a meaningful test result with assignment of the events to the respective test frequency. Subsequent design changes to the EUT can thus be qualified more quickly.

NSG 4070C TEST SYSTEM FOR CONDUCTED AND RADIATED IMMUNITY

Firmware: Immunity mode

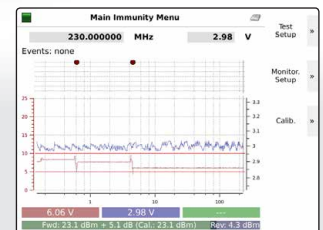
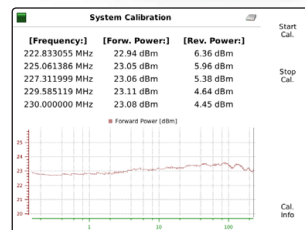
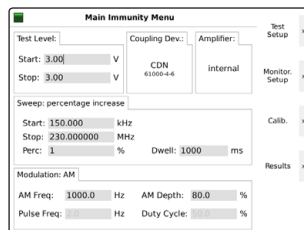

Configuration

Calibration

Testing



During the EMC tests, the test object undergoes different tests at different test stations. Among other things, short set-up times are an advantage so that the operating personnel can efficiently test the EUT. Switching on and testing expresses the wish of many users. With its unique menu-driven operation, the NSG 4070 fulfils this wish to operate tests according to IEC 61000-4-6 and simple automotive BCI tests from the front panel of the device. On-site testing of machines and systems is possible with the NSG 4070. The NSG 4070 contains configurations that the operator can load or modify according to the test being performed. This allows the parameter setting to be carried out with a user activity and in the shortest possible time. To execute a test, an existing system calibration file would have to be loaded or generated. Thanks to the very fast power meters and firmware optimized for fast measurement, the NSG 4070 takes less than a minute to calibrate for IEC 61000-4-6 with one-percent increments. During the test, the display changes to show the current frequency, level, EUT monitoring channels and their states. The response to EUT monitoring events can be adjusted. Irrespective of the EUT monitoring, the sweep can be interrupted with the "HOLD" key to manually change the frequency and level, for example, to further investigate the reaction of the DUT. Test results can be saved and reloaded as required. Based on a loaded test, tests can be repeated easily as the test configuration and system calibration data are included. When the test result is saved on a USB stick, a simple test report in PDF format and CSV format is also saved. The NSG 4070 Control Program offers extensive support for extended test report generation.

Firmware: Generator and Power Meter mode

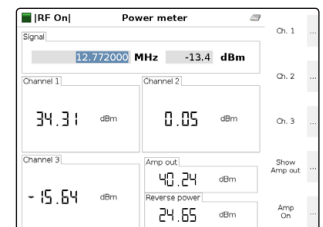
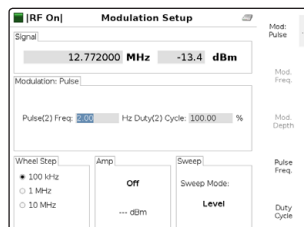

In addition to the Immunity menu for performing the EMC test, the NSG 4070, with two further menus, offers the option of operating the device as a stand-alone signal generator. The measured values of the power meters are displayed in the power meter menu. The operator can easily check his system and measure cables and attenuators.



Advanced Test Solutions for EMC

NSG 4070C TEST SYSTEM FOR CONDUCTED AND RADIATED IMMUNITY

Windows software NSG 4070 Control Program: Immunity mode

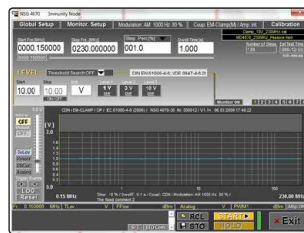

Configuration



Calibration

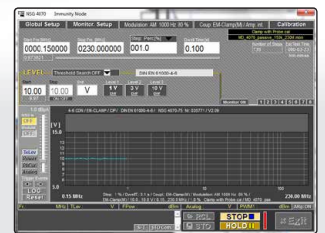

Testing

The supplied Windows program NSG 4070 Control allows remote control of the NSG 4070 at the same testing time as front panel operation. The same calibration files are used for simple tests with a constant level over the frequency range, both for operation via the front panel and for remote control via NSG 4070 Control. This allows the user to easily switch between the two modes of operation. The remote control program provides the user with additional functions for automated interference threshold search, for example to determine the appropriate PCB design or efficient interference suppression during development. The NSG 4070 Control can also switch the TTL outputs of the NSG 4070. This allows the integration of additional monitoring devices which are triggered at each frequency step, at an event or at the start of a test.

Generator mode, File menu and Show function

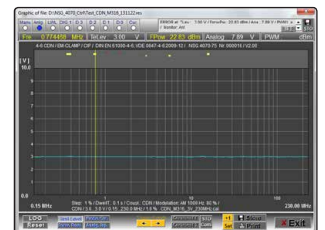
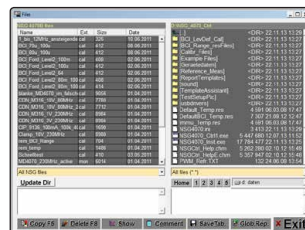
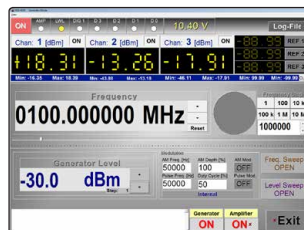

In addition to the Immunity menu for performing EMC tests, the NSG Control offers the option of operating the device as a stand-alone signal generator. The measured values of the power meters can be displayed. The range of functions for measuring the insertion loss of connected cables and attenuators with graphic evaluation is more extensive than for front panel operation. File operations between NSG 4070 and connected PC can be performed in the File menu. Test results can be supplemented manually or partially automatically with additional information. The test result can be loaded into a selected target design and saved as a test report at the push of a button. Both the predefined text modules and the target design can be adapted by the user. A conversion of the calibration files and results into ASCII format is supported.

NSG 4070C TEST SYSTEM FOR CONDUCTED AND RADIATED IMMUNITY

Optional Windows software icd.control

Pre-programmed Standard Test routines for fast and reliable testing

icd.control offers numerous Standard Test routines for various applications. With only a few steps a test is set up. Using Standard Test routines allows fast and reliable testing. The Standard Test routines can be modified and saved as user specific test routines in order to adopt special requirements, which go beyond the basic request without having to program such test routines from scratch. User specific test routines are composed easy, fast and efficient.

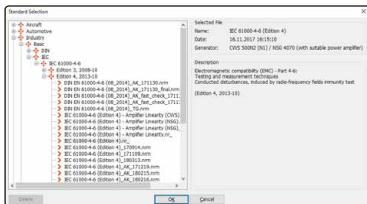

User Test routines - Programmed in vectors

Some test requirements may be too complex to be programmed in the common way. For such needs icd.control offers the vector programming mode. A test sequence can be specified with different vectors, each consisting of a start frequency/level and a stop frequency/level set of parameters. Even most complex requirements are easily set up and tested in the Vector mode.

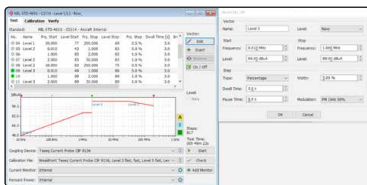

Implementation of external measuring instruments

External measuring equipment, e.g. Power Meter, Oscilloscope, Spectrum Analyser) can easily be implemented in the set-up for either measuring the injected RF test signal or for EUT monitoring during test. The data logger can handle almost every kind of measuring equipment having a GPIB interface. Up to four single channel instruments or any corresponding number of multi-channel equipment can be logged, each channel being individually controlled. Feedback signals from external instruments can be used as interrupts to control the test procedure.

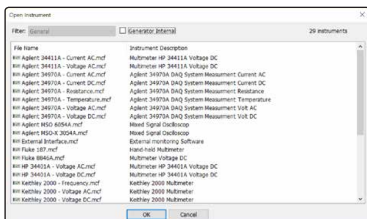

Enhanced reporting capability

icd.control offers an enhanced reporting capability. The complete test data including any comments entered in case of fail events is given in details. Graphics and data of the levelling, impedance characteristic and the recorded data from the used external measuring equipment can be included. Graphic information about the test set-up can be added for better documentation of the performed test. Test reports are automatically transferred into Rich-Text-Format (rtf) and can thus be easily post-processed by any software recognizing rtf format (e.g. Microsoft Word).

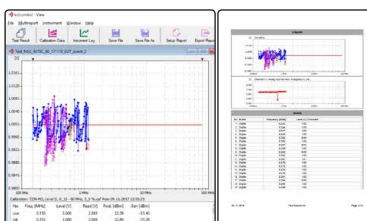

Advanced Test Solutions for EMC

NSG 4070C

TEST SYSTEM FOR CONDUCTED AND RADIATED IMMUNITY

Technical specifications

Generator

RF	
Frequency range:	4 kHz to 1 GHz
Resolution:	1 Hz
Reference frequency:	10 MHz
Aging:	25 ppm
RF Level	
Level range:	-60 dBm to +10 dBm
Resolution:	0.1 dB
Settling time:	10 ms
Amplitude modulation	
Modulation depth:	0 to 100%
Modulation frequency range:	1 Hz to 50 kHz
Frequency resolution:	1 Hz
Pulse modulation (possible to interlace up to three pulse modulations)	
Rise/fall time (10% / 90%):	< 1 μ s
Modulation frequency range:	0.01 Hz to 1 MHz
Frequency resolution:	0.01 Hz
Duty cycle:	0.1% to 100%
External modulation	
Delay time:	< 1 μ s / 180°
Period:	min. 20 μ s
Pulse width:	min. 10 μ s

Power meter

Frequency range:	4 kHz to 1 GHz
Linear measurement range	
channel 1:	-35 dBm to +27 dBm (NSG 4070C-60 and NSG 4070C-110: -40 dBm to +27 dBm)
channel 2,3:	-45 dBm to +20 dBm
Max. input / no damage	
channel 1-3:	+28 dBm
Noise level:	>5 dB below the measurement range
Input return loss:	>20 dB (below 500 MHz), >17 dB (500 MHz to 1 GHz)
Connector:	BNC socket, 50 Ω
Accuracy 10 to 30°C:	<0.5 dB, typ. <0.3 dB

NSG 4070C

TEST SYSTEM FOR CONDUCTED AND RADIATED IMMUNITY

Power amplifier

Nominal output power:	35 W	40 W (preliminary)		45 W	60 W (preliminary)		80 W	110 W (preliminary)		
Frequency range:	150 kHz to 230 MHz	10 kHz to 400 MHz		9 kHz to 1 GHz	10 kHz (4 kHz) to 400 MHz		150 kHz to 230 MHz	10 kHz (4 kHz) to 400 MHz		
Type:	single band, class A	single band, class A		single band, class A	single band, class A		single band, class A	single band, class A		
Input/output impedance (nominal):	50 Ω	50 Ω		50 Ω	50 Ω		50 Ω	50 Ω		
Input return loss (minimum):	10 dB	10 dB		10 dB	10 dB		10 dB	10 dB		
Output return loss without damage:	0 dB	0 dB		0 dB	0 dB		0 dB	0 dB		
Gain (minimum):	48 dB	10 kHz to 20 MHz 50 dB	20 MHz to 400 MHz 47 dB	50 dB	4 kHz to 10 kHz 45 dB	10 kHz to 400 MHz 53 dB	50 dB	4 kHz to 10 kHz 47 dB	10 kHz to 400 MHz 55 dB	
Gain flatness (maximum):	+/- 3 dB	+/- 3 dB		+/- 3 dB	+/- 3 dB		+/- 3 dB	+/- 3 dB		
Saturated output power (minimum):	45.4 dBm	10 kHz to 20 MHz 46 dBm	20 MHz to 400 MHz 44.5 dBm	< 400 MHz 46.5 dBm	> 400 MHz 45.4 dBm	4 kHz to 10 kHz 42 dBm	10 kHz to 400 MHz 49 dBm	49 dBm	4 kHz to 10 kHz 43 dBm	10 kHz to 400 MHz 50.4 dBm
Linear output power (minimum):	44 dBm	10 kHz to 20 MHz 45 dBm	20 MHz to 400 MHz 43 dBm	< 400 MHz 45.4 dBm	> 400 MHz 43 dBm	4 kHz to 10 kHz 40 dBm	10 kHz to 400 MHz 48 dBm	48 dBm	4 kHz to 10 kHz 41 dBm	10 kHz to 400 MHz 49 dBm
Input power without damage (maximum):	+10 dBm	+10 dBm		+10 dBm	+10 dBm		+10 dBm	+10 dBm		
Harmonic distortion at linear output power (typical):	< -17 dBc	< -20 dBc		< -20 dBc	< -18 dBc		< -20 dBc	< -20 dBc		

NSG 4070C TEST SYSTEM FOR CONDUCTED AND RADIATED IMMUNITY

Power amplifier of NSG 4070C-35

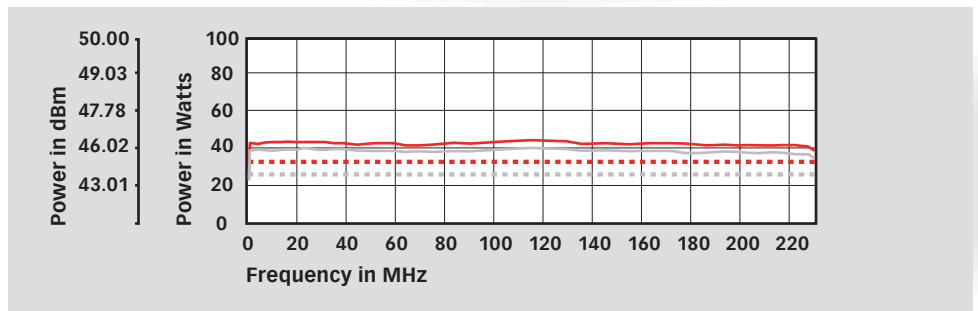

Power amplifier of NSG 4070C-40 (preliminary data)

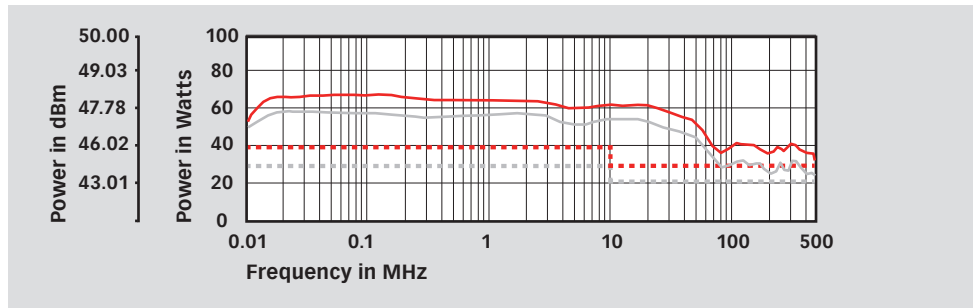

Power amplifier of NSG 4070C-45

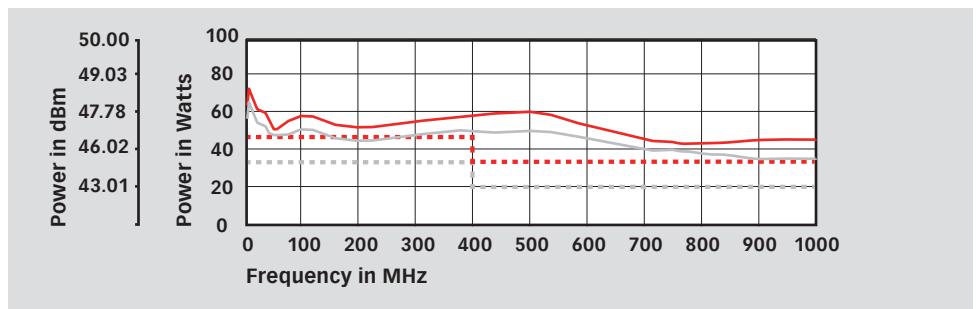

Legend

- typical saturated power
- typical linear power
- - - specification saturated power
- - - specification linear power

NSG 4070C TEST SYSTEM FOR CONDUCTED AND RADIATED IMMUNITY

Power amplifier of NSG 4070C-60 (preliminary data)

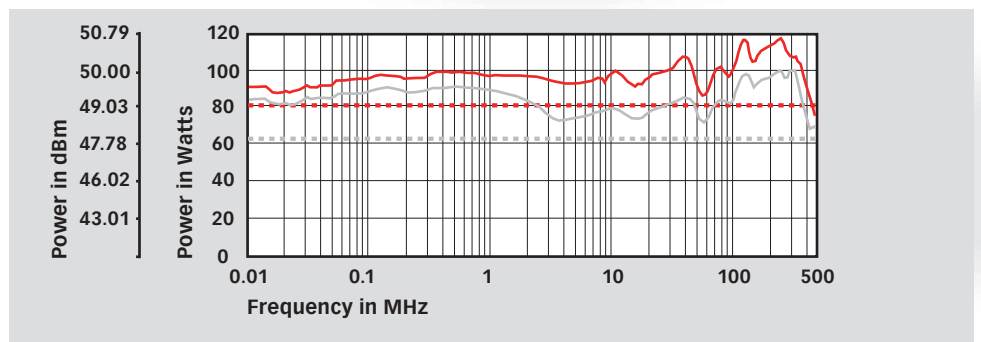

Power amplifier of NSG 4070C-80

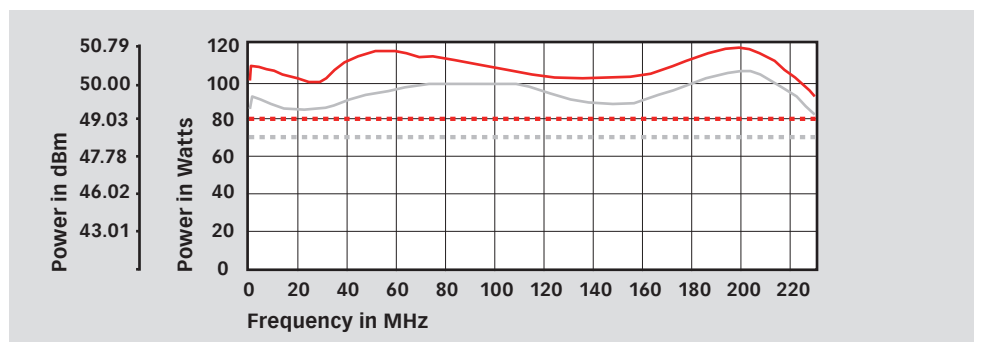

Power amplifier of NSG 4070C-110 (preliminary data)

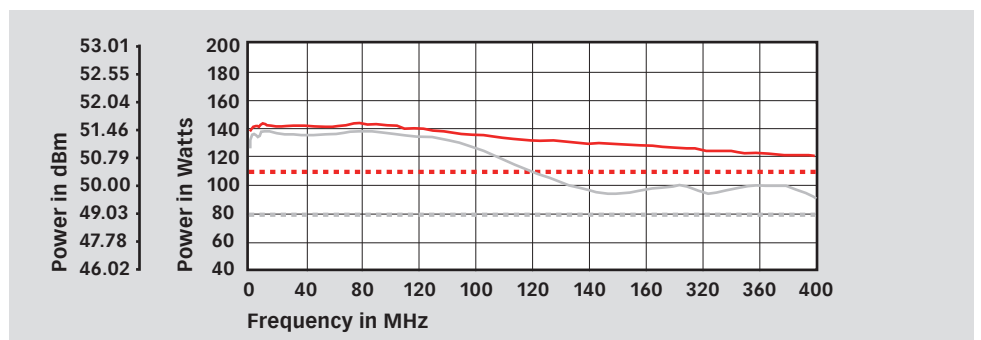

- Legend**
- typical saturated power
 - typical linear power
 - - - specification saturated power
 - - - specification linear power

NSG 4070C

TEST SYSTEM FOR CONDUCTED AND RADIATED IMMUNITY

Test and measurement routines

Firmware: Generator mode

Sweep:	Frequency sweep, level sweep
Modulation:	AM, AM PC (peak conservation), pulse modulation and external
Others:	Free parameter setting from 9 kHz to 1 GHz, high power mode using power amplifier

Firmware: Immunity mode

Level:	start and stop level or sections can be defined, max test levels depending on power amplifier or for IEC 61000-4-6 limited to 30 V EMF, for BCI tests levels in units mA or dB μ A
Test methods IEC 61000-4-6:	CDN, EM clamp, current clamp and direct injection, clamp injection with test level control using monitoring probe
Test methods BCI:	substitution method with optional use of the monitoring probe, closed loop method with power limitation (factor adjustable)
Sweep:	frequency or section sweep with linear, steps per decade or percentage increase
Modulation:	AM, AM PC (peak conservation), pulse modulation, external or mixed (e.g. 1 kHz AM internal modulated with 1 Hz PM external)
EUT monitoring:	Individual configuration of the port's functionality, display of events during the test, in the result file and in the test report
Calibration:	Test set-up and monitoring probe calibration, display, store and recall function of calibration files (limitation of file numbers only by the disk space, typical >340 files)
EUT threshold search:	Manual search by changing frequency or stress level
Store and recall:	Store and recall function of test configurations, calibration results and test results (number of files is only limited by the disk space, typical >340 files), supports USB sticks
Component check:	Quick check of system components, e.g. cable, attenuator max. 52 dB/54 dB/58 dB attenuation for 35 W/45 W/80 W amplifier, max. +16 dB gain at 27 dBm output level
Amplifier saturation check:	Validation that the power amplifier is not in saturation for the selected test level including 80% AM, see IEC 61000-4-6 Ed. 4 for more information (only available for firmware operation)
Additional features:	Free parameter setting from 9 kHz to 1 GHz, supports external power amplifier, RF switch SW 4070, monitoring probe MD 4070, directional coupler and attenuator

NSG 4070C TEST SYSTEM FOR CONDUCTED AND RADIATED IMMUNITY

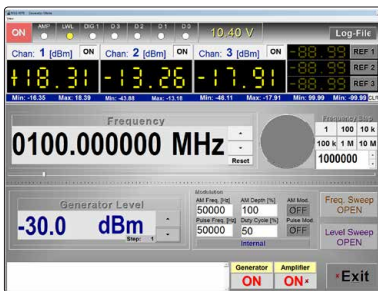

Windows software

General:	The windows software includes the firmware functionality. The following additional features are available see below. The software allows the use of the report generator and all post processing features without the remote connection to the NSG 4070.
Remote control:	Remote control of NSG 4070 via LAN, USB or RS232
Data transfer:	Transfer between NSG 4070 and PC via remote connection or with USB stick

Software: Generator menu



Windows software: Generator mode

Display:	Power meter display (units dBm, V, dBμV) with reference value setting, min./max. display and export to a log file (frequency, time, power), EUT monitoring display
Single step mode:	Synchronized frequency sweep with power measurement, output as graph and ASCII file (application: scalar analysis on quadripole networks)

Software: Immunity test setup

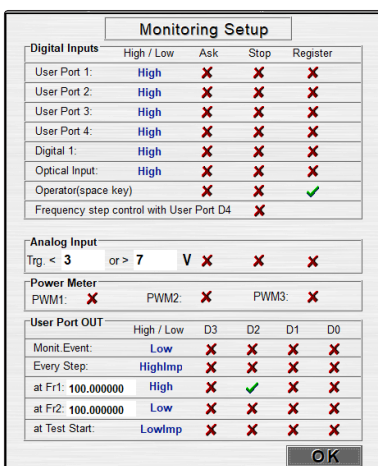

Windows software: Immunity mode

Sweep:	Level sweep with start and stop value or with free editable table, level profile editor and sweep function for BCI tests
EUT threshold search:	Different opportunities for manual and automatic control
EUT monitoring:	Power meter use as EUT monitoring device, keyboard activity for test interrupt with possibility for writing test report comments (EUT reaction etc.), output control for user port
Additional features:	For each frequency step or each monitoring event output control for user port (to control a RF switch for the use of two amplifier)
One click report generation:	Tool for test report generation in rtf format, works with different user changeable templates, post processing of measurement data (input for test conditions, EUT parameters and comments), free changeable structure and items of the report, user support of repetitive inputs
Export function:	Result and calibration files can be converted to txt files, graphs can be zoomed and converted to jpg files

Software: EUT monitoring setup



Advanced Test Solutions for EMC

NSG 4070C TEST SYSTEM FOR CONDUCTED AND RADIATED IMMUNITY



NSG 4070 front panel with RF ports

Analog ports

Front panel	
Generator output:	N socket 50 Ω , 4 kHz to 1 GHz
Power amplifier input:	N socket 50 Ω , max. +10 dBm
Power amplifier output:	N socket 50 Ω
Power meter channel 1 to 3:	as defined in chapter "Power meter"
Back panel	
Monitoring input analog:	BNC socket, 0 to 24 V Ri=15 k Ω , 6 mV resolution
External modulation input:	BNC socket, impedance >10 k Ω , level: 1 Vpp to get 100% AM, 1 Hz to 50 kHz
10 MHz reference output:	BNC socket, approx. 1 Vpp/50 Ω

Digital ports

Front panel	
USB:	USB host connector for USB stick, keyboard, mouse
Back panel	
User port:	D-Sub 15 pole 4 TTL inputs 4 TTL outputs +12 V / 800 mA, -12 V / 200 mA, +5 V / 800 mA power supply
Monitoring digital input:	BNC socket 0 to 24 V via optical coupler Ri=1.5 k Ω , switching threshold approx. 2 to 3 V
Monitoring optical input:	LWL (Light wave connector), HP versatile link HFBR0501 series 40 kBd, (avoid scattered light on the back panel)
Trigger input:	BNC socket, TTL for external triggering, max. frequency 100 Hz, trigger delay <10 ms
RS232:	D-Sub 9 pole, up to 115200 Bd
RS232 optical:	Connector 2 x HFBRx523 socket for 1 mm fiber optic cable with length between 5 m and 30 m with 115200 Bd, for other distances 38400 Bd, max. 50 m
2x USB:	USB host connector for USB stick, keyboard, mouse
USB device connector:	For remote control
Network:	RJ45, Ethernet 10/100 BASE-T

NSG 4070C TEST SYSTEM FOR CONDUCTED AND RADIATED IMMUNITY

Power supply

Power consumption	100 to 240 VAC 50/60 HZ autoranging	Recommended fuse F1 for nominal 110 V	Recommended fuse F1 for nominal 230 V
NSG 4070C-0	approx. 80 W	1 A (slow)	0.5 A (slow)
NSG 4070C-35, -40, -45, -60 and -80	approx. 415 W	6.3 A (slow)	2.5 A (slow)
NSG 4070C-110 Generator: Power amplifier:	approx. 80 W <1 kW	1 A (slow) 10 A (slow)	0.5 A (slow) 10 A (slow)

General data

Operating temperature range:	0 °C to 40 °C
Storage temperature range:	-20 °C to 60 °C
Relative humidity:	95 % / 30 °C (no moisture condensation)
EMC:	DIN/EN 61326-1:2006
Shock:	DIN/EN 60068-2-27
Vibration:	DIN/EN 60068-2-6
Protection class:	DIN/EN 61010-1/IEC 61010-1

Mechanical specifications (except NSG 4070C-110)

Size (W x H x D):	45 cm (19") x 15 cm (3HU) x 42.3 cm (with handle bar and foot)
Weight:	approx. 15 kg (with internal power amplifier), approx. 8 kg (without internal power amplifier)
Size of cardboard box:	80 cm x 61 cm x 34 cm (also for options ATN 60xx and/or LE 4070 additional space available)
Weight of cardboard box:	approx. 8 kg (empty)

Mechanical specifications (NSG 4070C-110)

Size (W x H x D):	65 cm x 46 cm x 60 cm
Weight:	approx. 44 kg

NSG 4070C TEST SYSTEM FOR CONDUCTED AND RADIATED IMMUNITY

Application for IEC/EN 61000-4-6, calibration set-up with CDN

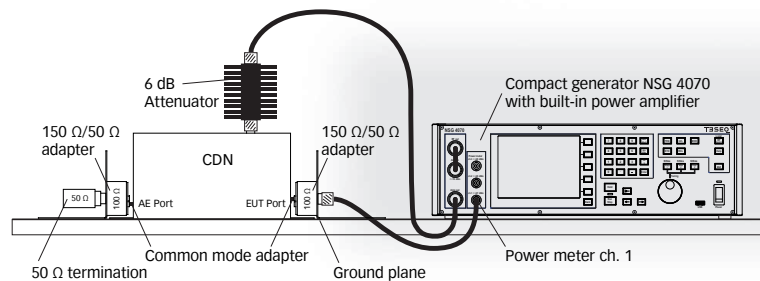

Application for IEC/EN 61000-4-6, EUT set-up with CDN

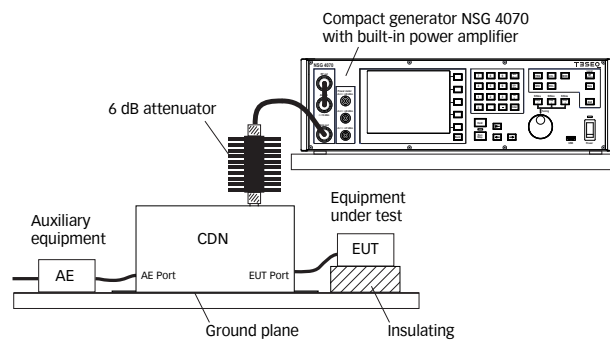

Application for IEC/EN 61000-4-6, calibration set-up with EM clamp

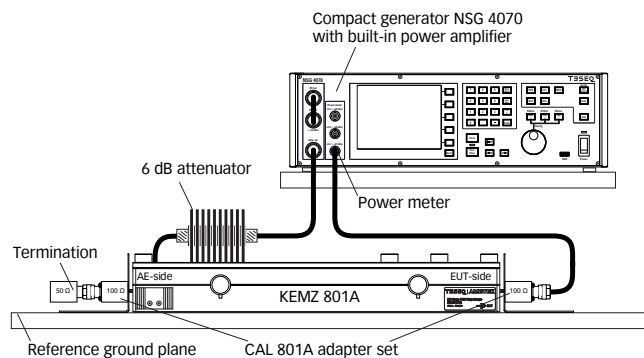

NSG 4070C TEST SYSTEM FOR CONDUCTED AND RADIATED IMMUNITY



LE 4070, RF cable set for NSG 4070, consist of:

- RF cable, N(m)-N(m), 3 m with one right-angle plug, RG223;
- RF cable, N(m)-BNC(m), 2 m, RG223;
- RF cable, BNC(m)-N(m), 250 mm;
- RF cable, N(m)-N(m), 120 mm;
- Adapter N(m)-N(m);
- Adapter N(f)-BNC(m)

Application for IEC/EN 61000-4-6, calibration set-up with current injection probe

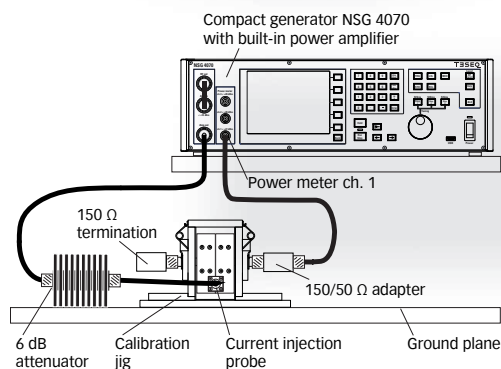

Application for IEC/EN 61000-4-6, EUT set-up with EM clamp or current injection probe and for example with use of a monitoring probe

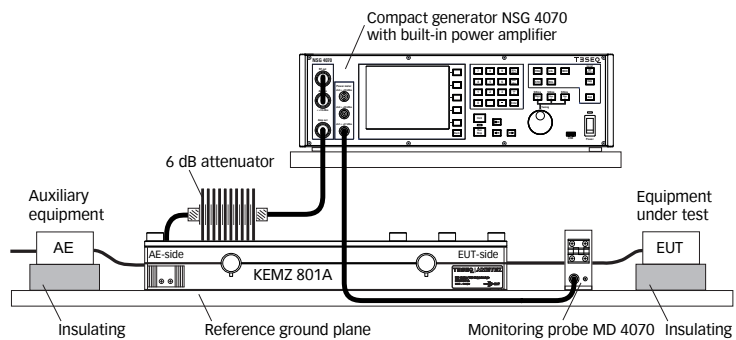

NSG 4070C TEST SYSTEM FOR CONDUCTED AND RADIATED IMMUNITY



NSG 4070C-110

Application for automotive BCI, calibration set-up (example with NSG 4070C-110)

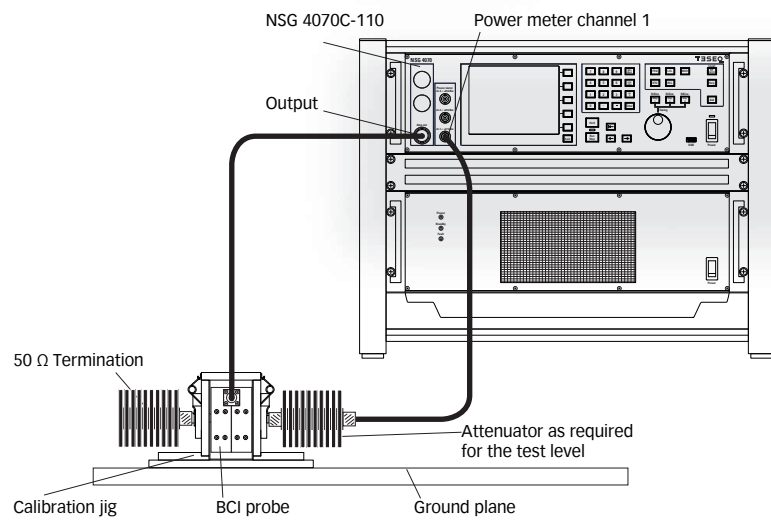

Application for automotive BCI, EUT set-up with monitoring probe and LISN (example with NSG 4070C-110)

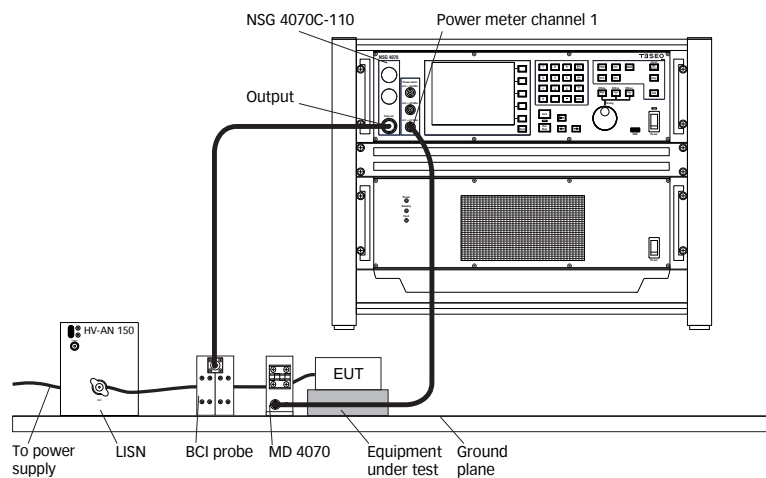

NSG 4070C TEST SYSTEM FOR CONDUCTED AND RADIATED IMMUNITY



NSG 4070-0 combined with RF switch network and power amplifiers for a complex solution up to 1 GHz

Application for automotive BCI, calibration set-up (example with external power amplifier and directional coupler)

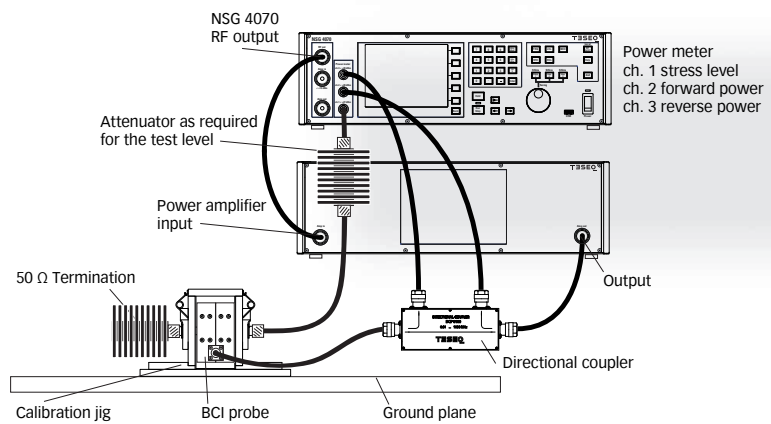

Application for automotive BCI, EUT set-up with monitoring probe (example with external power amplifier and directional coupler)

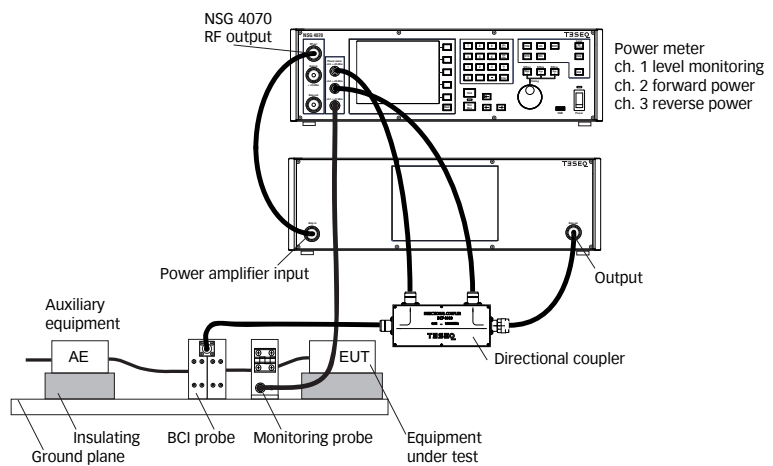

NSG 4070C TEST SYSTEM FOR CONDUCTED AND RADIATED IMMUNITY

Application for automotive BCI, calibration set-up (example with NSG 4070C-60)

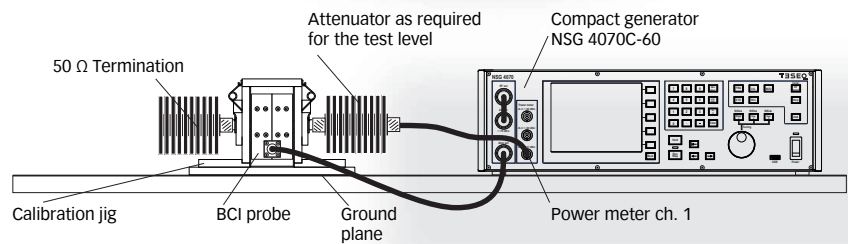

Application for automotive BCI, EUT set-up with monitoring probe and LISN (example with NSG 4070C-60)

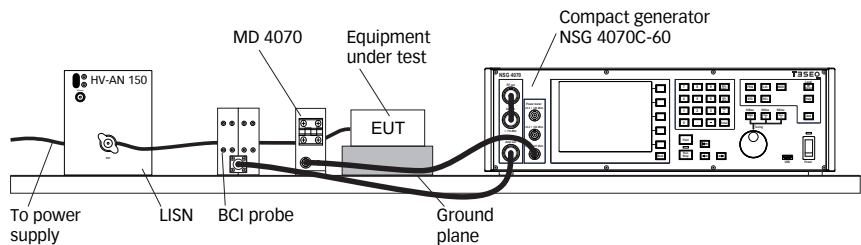

Application for IEC / EN 61000-4-20 up to 1 GHz (example with NSG 4070-45; field probe control requires optional software e.g. WIN 6000)

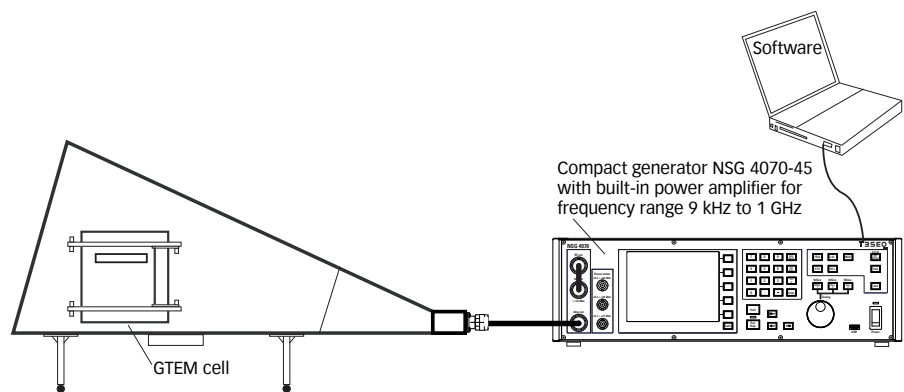

NSG 4070C TEST SYSTEM FOR CONDUCTED AND RADIATED IMMUNITY



NSG 4070

Delivery items for the NSG 4070 series

Compact immunity test system NSG 4070, 4 kHz to 1 GHz RF generator and power meter (power amplifier as selected); remote control software on USB stick; spare fuses (2); RS232 cable (Nullmodem); USO 4013 (USB to serial/optical converter with 20 m optical cable); LAN cable, crossover, 3 m; keyboard (English); mains cable GB, CH, USA/JP, EU; operating manual



NSG 4070 with rack mounting kit



NSG 4070C-110

Model No. and options

Part number	Description
257495	NSG 4070C-0 Compact immunity test system 4 kHz to 1 GHz RF generator and power meter (without power amplifier)
257491	NSG 4070C-35 Compact immunity test system, 4 kHz to 1 GHz RF generator and power meter (with 35 W module 150 kHz to 230 MHz)
257493	NSG 4070C-40 Compact immunity test system, 4 kHz to 1 GHz RF generator and power meter (with 40 W module 10 kHz to 400 MHz)
257494	NSG 4070C-45 Compact immunity test system, 4 kHz to 1 GHz RF generator and power meter (with 45 W module 9 kHz to 1 GHz)
257408	NSG 4070C-60 Compact immunity test system, 4 kHz to 1 GHz RF generator, 4 kHz to 1 GHz 5-channel power meter (3 inputs, 2 used internal), 60 W power ampl. module 10 kHz to 400 MHz (>10 W 4 to 10 kHz)
257492	NSG 4070C-80 Compact immunity test system NSG 4070, 4 kHz to 1 GHz RF generator and power meter (with 80 W module 150 kHz to 230 MHz)
257499	NSG 4070C-110 Compact immunity test system, 4 kHz to 1 GHz RF generator, 4 kHz to 1 GHz 5-channel power meter (3 inputs, 2 used internal), 110 W power ampl. module 10 kHz to 400 MHz (>10 W 4 to 10 kHz)
97-253290	NSG 4070-TC Traceable calibration (ISO17025), order only with the device
98-253290	NSG 4070-DAkKS DAkKS calibration (ISO17025), order only with the device
253840	NSG 4070 Rack Rack mounting kit for NSG 4070 (red handles) (Not valid for NSG 4070C-110)

NSG 4070C TEST SYSTEM FOR CONDUCTED AND RADIATED IMMUNITY



SW 4070, RF switch network 2xSPDT



ATN 6150, 6 dB attenuator 150 W

Model No. and options (continued)

253850	SW 4070 Option for NSG 4070: RF-Switch network 2x SPDT
253104	LE 4070 RF cable set for NSG 4070
235380	ATN 6060 6 dB Attenuator 60 W cw N(f)-N(f)
235376	ATN 6150 6 dB Attenuator 150 W cw N(f)-N(f)
235378	ATN 6200 6 dB Attenuator 200 W cw N(f)-N(f)
257512	icd.control Software License for one generator NSG 4070B-xx, NSG 4070C-xx

Example icd.control software

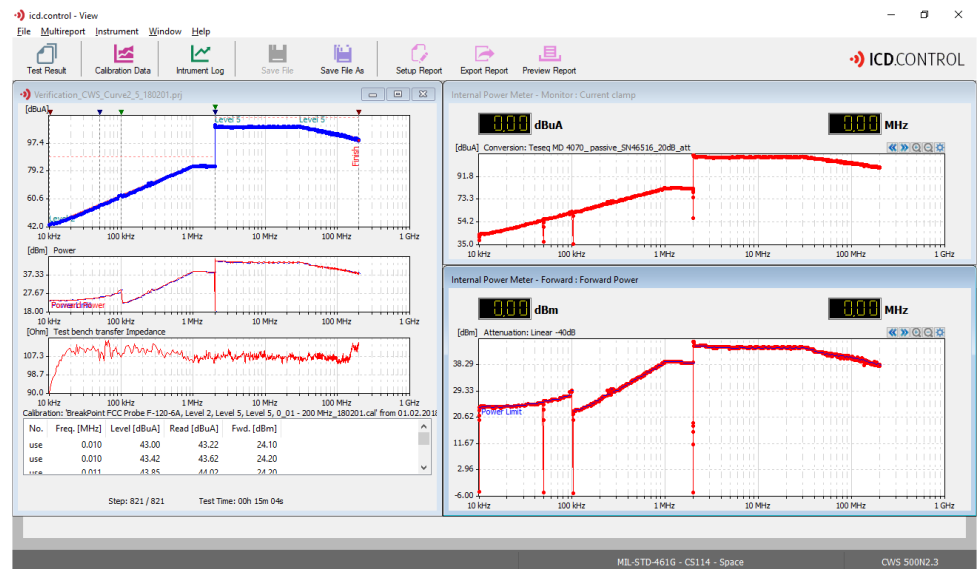

© December 2018 Teseq®
Specifications subject to change without notice. Teseq® is an ISO-registered company. Its products are designed and manufactured under the strict quality and environmental requirements of the ISO 9001. This document has been carefully checked. However, Teseq® does not assume any liability for errors or inaccuracies.

82-257492 E05 December 2018